



EZ Flush

Automatic Sensor Retrofit Kit For Urinals and Toilets

ZERK-CP Chrome-Plated Cover

ZERK-CPM Chrome-Plated Metal Cover



INSTALLATION INSTRUCTIONS

⚠ WARNING: Cancer and Reproductive Harm - www.P65Warnings.ca.gov

⚠ ADVERTENCIA: Cáncer y daño reproductivo - www.P65Warnings.ca.gov

⚠ AVERTISSEMENT: Cancer et effets néfastes sur la reproduction - www.P65Warnings.ca.gov

Zurn Industries, LLC
511 W. Freshwater Way, Milwaukee, WI U.S.A. 53204 · Ph. 1-855-ONE-ZURN, Fax 919-775-3541
In Canada | Zurn Industries Limited
7900 Goreway Drive Unit 10, Brampton, Ontario L6T5W6 · Ph. 905-405-8272, Fax 905-405-1292

Rev. B
Date: 10/30/2018
C.N. No. SAN008373
Prod. | Dwg. No. FV2001

1 DESCRIPTION

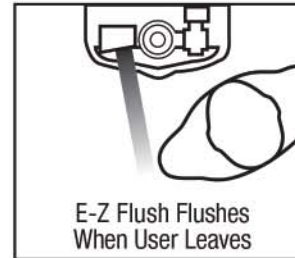
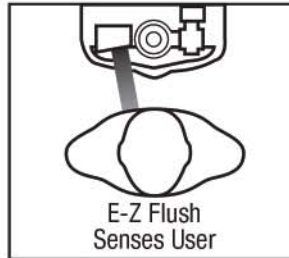
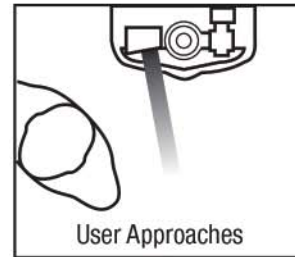
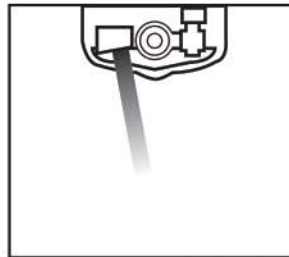
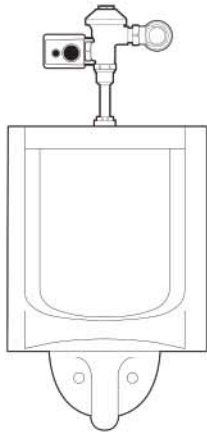

The E-Z Flush™ sends out a continuous infrared beam that is reflected back by the presence of a person in front of the urinal or toilet. The technology differentiates between someone walking past the unit or actually using the fixture. E-Z Flush models ZERK-CP and ZERK-CPM retrofit Zurn and Sloan valves. For Delaney valves, order model ZERK-CP-LY or ZERK-CPM-LY.

2 E-Z FLUSH COMPONENTS

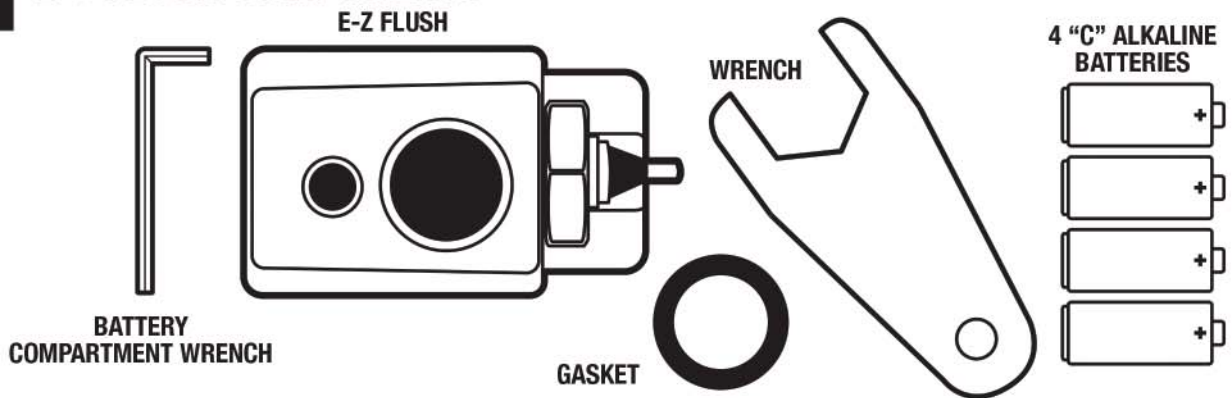

3 INSTALLATION

Shut off water supply at stop.

A – Using the supplied wrench, loosen handle nut.

B – Remove handle from flush valve.

Note: A small amount of water may drip from the port.

C – Place gasket into nut and attach the E-Z Flush unit where the handle was removed.

D – Tighten nut with supplied wrench.

Note: Save handle in the event you wish to reuse for service of E-Z Flush.

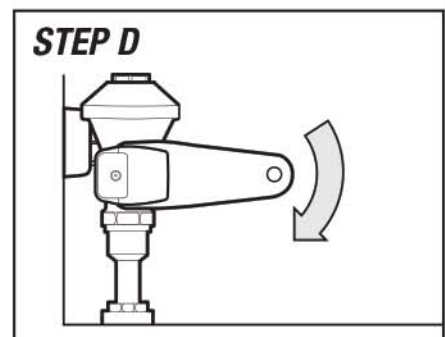
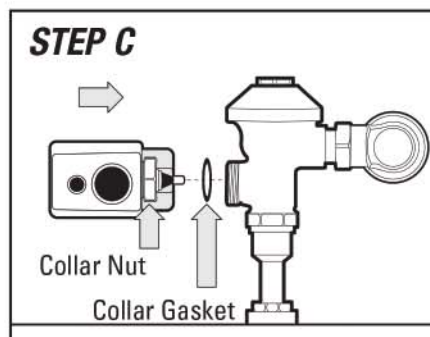
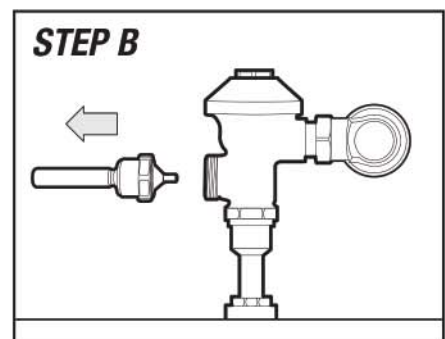
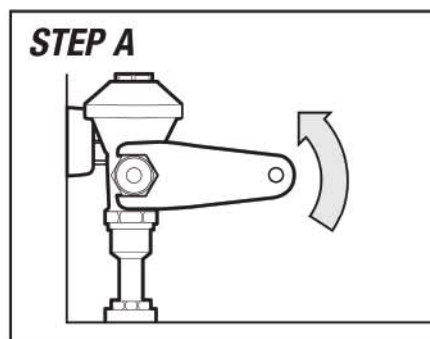

4 ACTIVATION



Using supplied battery compartment wrench, remove battery compartment from the E-Z Flush™ unit.

Load batteries into compartment tray (note position of batteries in tray), and reinstall battery tray into the E-Z Flush unit.

Secure tray with battery compartment wrench. The last three turns of the wrench will activate the E-Z Flush unit. The E-Z Flush System is now operational.

Your E-Z Flush unit comes preset from the factory. If special circumstances require adjustment of the activation distance, see Step 7 – “To Change Sensor Activation Distance.”

The E-Z Flush unit has a 10-minute start-up sequence in which the sensor will flash the User-In-View **yellow L.E.D.** continuously as long as a user is in view. After the start-up sequence is completed and when the sensor has a user in view, the User-In-View **yellow L.E.D.** will flash only 3 times after a 5-second delay. This delay prevents needless flushes when someone walks by.

Remove Battery Compartment

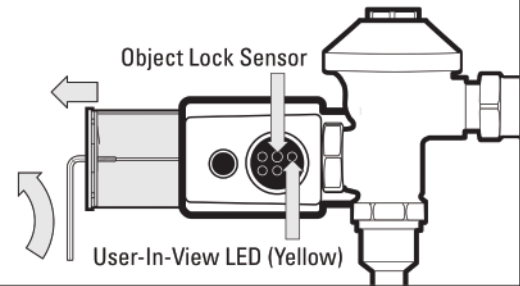

Install Battery Compartment

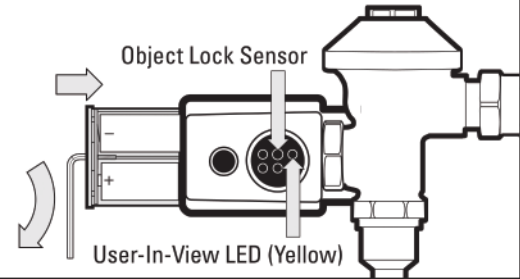

5 VISUAL INDICATOR GUIDE

USER-IN-VIEW L.E.D. Yellow light flashes 3 times – after 5-second delay – when a user is in view. The yellow light flashes constantly when a user is in view during the 10-minute start-up sequence.

SENSOR

BATTERY L.E.D. Red light flashes indicating it is time to replace batteries with 4 new “C” batteries.

COURTESY MANUAL FLUSH BUTTON Allows manual activation of flush when needed.

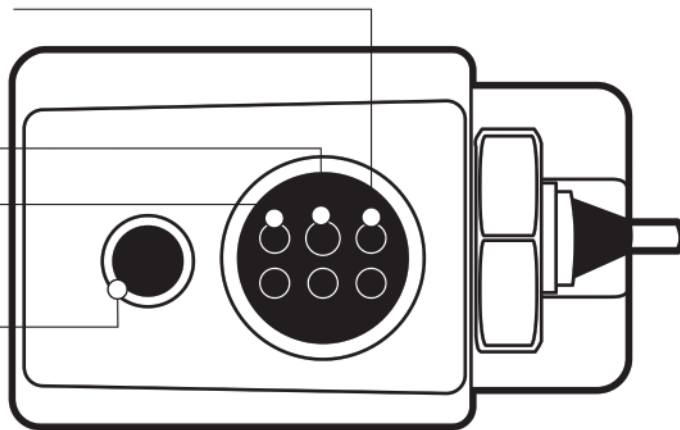

6 ADJUSTING YOUR E-Z FLUSH

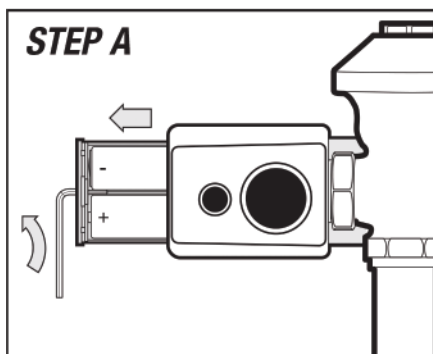

Use battery compartment wrench to remove battery compartment tray.

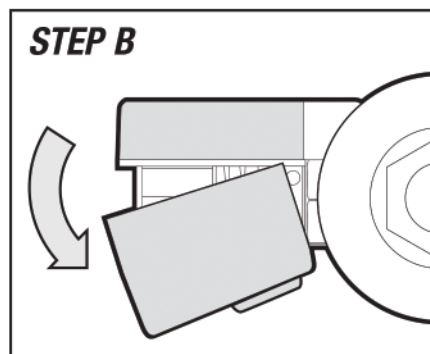

Pull cover off by rotating battery side forward and out.

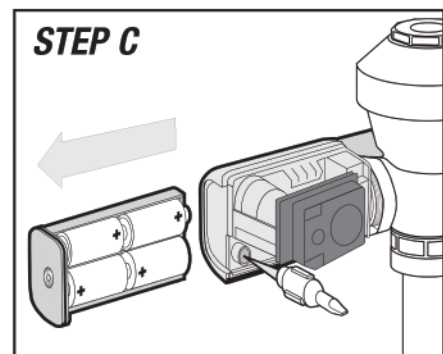

Sensor Adjustor Tool comes in a built-in storage pocket. Replace after use.

7 TO CHANGE SENSOR ACTIVATION DISTANCE

1. Remove battery compartment tray as shown in Step 6.
2. Remove cover and sensor adjustor tool as shown in Step 6.
3. Replace battery compartment in E-Z Flush to activate unit (the yellow L.E.D. will flash continuously when it has an object in view for the 10-minute reset period). See Step 4 – “Activation.”
4. Have an individual stand at desired activation distance.
5. Use sensor adjustor tool and turn the **Sensor Range Adjustment Screw** all the way down and then turn slowly up until **yellow L.E.D.** begins to flash.
6. Ensure sensor is not detecting stall door or wall by closing door, stepping out of sensor path and making sure **yellow L.E.D.** is not flashing. If sensor locks onto door or wall, unit will not flush properly. Shorten activation distance.
7. Remove battery compartment, replace sensor adjustor tool and cover. Replace battery compartment tray to reactivate E-Z Flush unit.
8. After 10-minute start-up sequence, the **yellow L.E.D.** will flash only 3 times when a user is in view (after a 5-second delay).

8 WIRING DIAGRAM

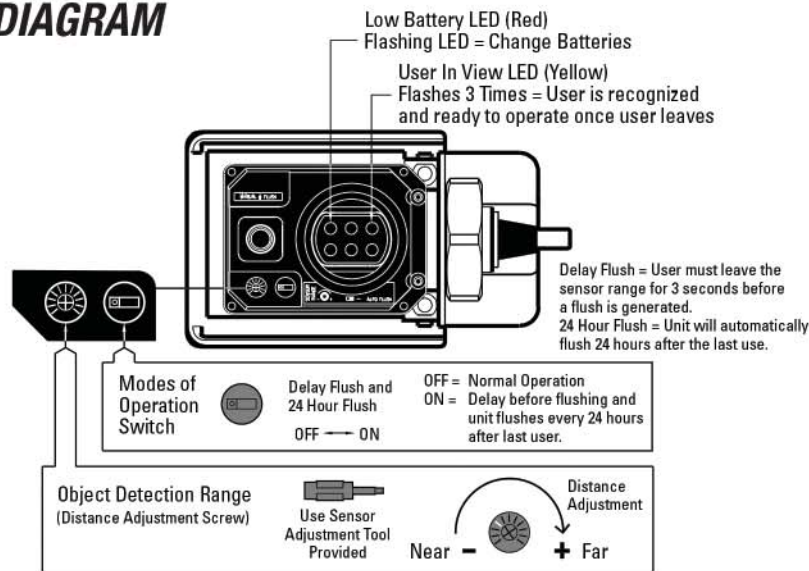

9 TROUBLESHOOTING GUIDE

PROBLEM	CAUSE	SOLUTION TO PROBLEM
Yellow L.E.D. light flashes 3 times when there are no users.	Front of sensor is covered or sensor is set too far out, registering the opposite wall or door as a user.	Remove item covering sensor or adjust sensor activation distance. (See Step 7 – “To Change Sensor Activation Distance.”)
Yellow L.E.D. light flashes continuously when sensor is activated by a user.	E-Z Flush unit is in 10-minute start-up mode (when first activated).	Yellow L.E.D. light will flash only 3 times, acknowledging a user is in view after the 10-minute start-up mode.
Red L.E.D. light flashes.	Batteries need replacing.	Replace batteries.
Not enough water to fixture or too much water to fixture.	Diaphragm damaged or valve control stop improperly adjusted.	Replace diaphragm and/or adjust valve control stop.
Valve will not operate.	Sensor range set too close to E-Z Flush, batteries are dead, or water supply is turned off.	Adjust sensor, replace batteries, or turn water on. If the E-Z Flush does not begin to function, call Customer Service at 1-800-997-3876.
Valve does not shut off.	Dirt or debris preventing diaphragm from functioning properly.	Remove dirt or debris, consult valve manufacturer's directions.
Valve does not flush even after sensor has been adjusted.	Batteries are dead.	Replace batteries. If the E-Z Flush does not begin to function, call Customer Service at 1-800-997-3876.

ZURN INDUSTRIES, LLC. COMMERCIAL BRASS OPERATION

5900 ELWIN BUCHANAN DRIVE, SANFORD, NC, U.S.A. 27330 PHONE: 1-800-997-3876 FAX: 919/775-3541 WEBSITE: www.zurn.com
ZURN INDUSTRIES LIMITED 3544 NASHUA DRIVE, MISSISSAUGA, ONTARIO L4V 1L2 PHONE: 905/405-8272 FAX: 905/405-1292