

SINGLE-STATION MOUNTING FRAME INSTRUCTIONS

ACTUAL FRAME MAY VARY FROM THE ONE ILLUSTRATED. PLEASE REFER TO THE INSTALLATION/OWNERS MANUAL OF THE SPECIFIC UNIT FOR ADDITIONAL INFORMATION.

MF100

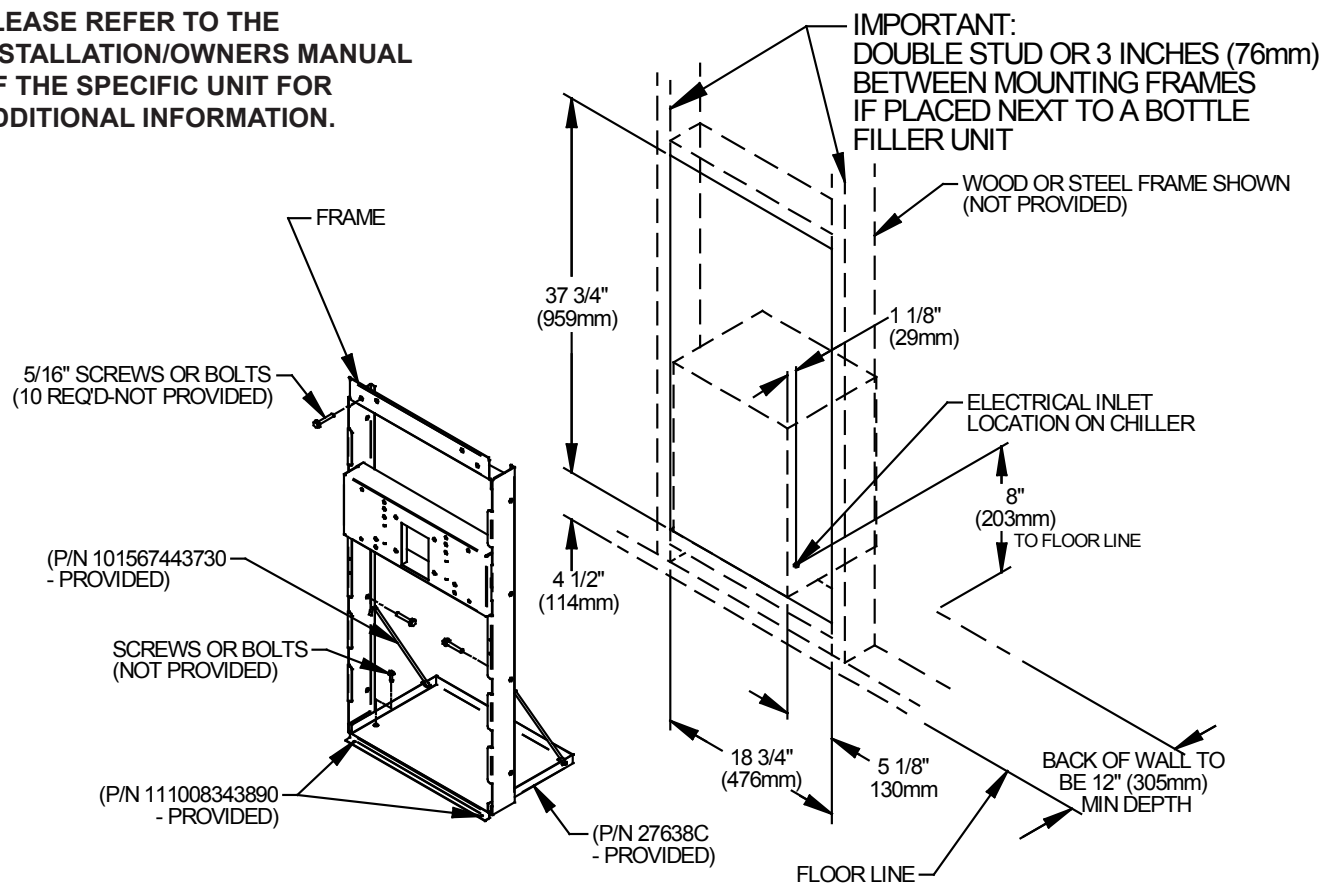

- Cut a square rectangular wall opening** 18 3/4" (476mm) W x 37 3/4" (959mm) H and 4 1/2" (114mm) above the floor line. These dimensions are required to obtain proper rim and bubbler heights for compliance with ANSI standard A117.1.
- Reinforce the wall opening** on all sides so that it will adequately support the water fountain. This reinforcement must support up to 150 lbs static load and provide a means for securing the frame assembly in place.
NOTE: Building construction must allow for adequate air flow on both sides and top of remote chiller unit. Minimum of 4" (102mm) is required.
- Install plumbing and electrical rough-ins.** A junction box for a (3) wire, 10 amp branch circuit is provided on the inside of the chiller. (Standard 120 Volts, 60 Hz and single phase)
- Remove frame and related hardware** from packaging. Release the two shelf rods by cutting cable ties. Install the frame squarely in wall opening with frame upright edges flush with the finished wall face. Place shelf inside frame and line up the (2) holes on each. Insert loose ends of rods into holes on sides of shelf panel. Using appropriately sized screws or bolts (not provided), fasten the shelf and frame to bottom of wall opening. Secure the frame sides and top to the wall using (10) 5/16" bolts or screws (not provided).
NOTE: Be sure that frame is squared in location. Do not use less than the required screw quantity and size.

For Technical Service, please contact us at 1.800.476.4106

DUAL-STATION MOUNTING FRAME INSTRUCTIONS

MF200

ACTUAL FRAME MAY VARY FROM THE ONE ILLUSTRATED. PLEASE REFER TO THE INSTALLATION/OWNERS MANUAL OF THE SPECIFIC UNIT FOR ADDITIONAL INFORMATION.

REVERSED CONFIGURATION:
HIGHER UNIT ON THE RIGHT

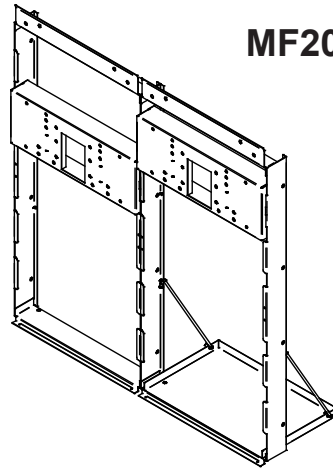

IMPORTANT:
DOUBLE STUD OR 3 INCHES (76mm) BETWEEN MOUNTING FRAMES IF PLACED NEXT TO A BOTTLE FILLER UNIT

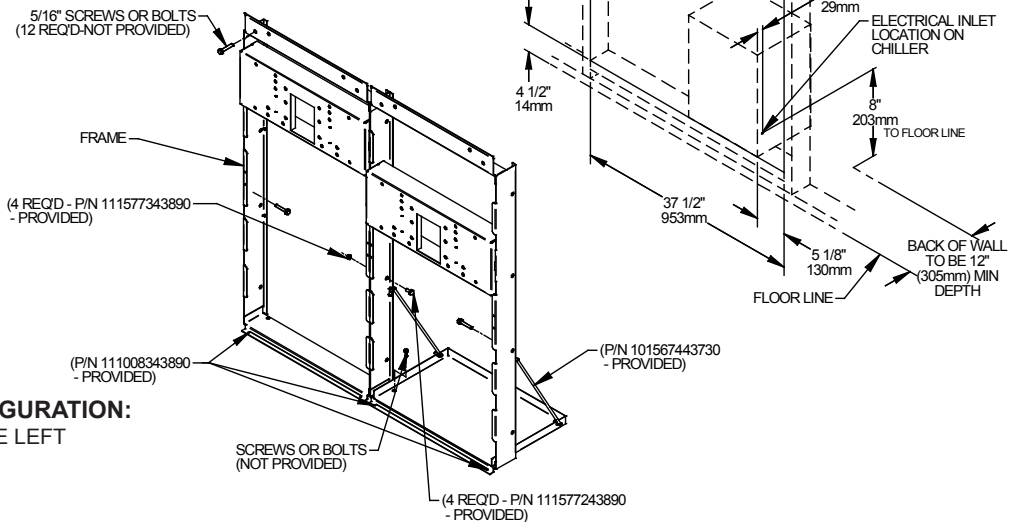

STANDARD CONFIGURATION:
HIGHER UNIT ON THE LEFT

1. **Cut a square rectangular wall opening** 37 1/2" (953mm) W x 37 3/4" (959mm) H and 4 1/2" (114mm) above the floor line. These dimensions are required to obtain proper rim and bubbler heights for compliance with ANSI standard A117.1.
2. **Reinforce the wall opening** on all sides so that it will adequately support the water fountain. This reinforcement must support up to 150 lbs static load and provide a means for securing the frame assembly in place. **NOTE:** Building construction must allow for adequate air flow on both sides and top of remote chiller unit. Minimum of 4" (102mm) is required.
3. **Install plumbing and electrical rough-ins.** A junction box for a (3) wire, 10 amp branch circuit is provided on the inside of the chiller. (Standard 120 Volts, 60 Hz and single phase)
4. **Remove frame assembly and related hardware** from packaging. Attach the two frames together thru the upright supports with (4) 5/16" x 3/4" (19mm) long bolts and nuts (provided). Tighten securely.
5. **Install the frame assembly** squarely in wall opening with frame upright support edges flush with the finished wall face. Secure the frame to the wall thru holes with (12) 5/16" bolts or screws (not provided). Tighten securely. **NOTE:** Be sure that frame is squared in location. Do not use less than required screw quantity and size.
6. **Attach the chiller shelf support rods** to the right side frame uprights at the second set of holes counting from the bottom and to the shelf at the (2) side holes. Line up the other shelf holes with the frame bottom holes and fasten the assembly to the wall using appropriately sized screws or bolts and nuts (not provided).

For Technical Service, please contact us at 1.800.476.4106