

PRODUCT SPECIFICATIONS

Elkay's self-contained, *Touchless* hand washing station. Includes touchless electronic faucet, touchless soap and touchless towel dispensers. On-demand water heater, 5 gallon fresh water tank and 6 gallon waste water tank conveniently contained within the mobile cabinet.

Model	MHS2424HF
Faucet*	ELKAY Commercial Electronic Faucet Model LKB737C, Sensor Activated with auto shut off
Flow Rate	0.5 GPM
Cabinet Dimensions (LxWxH) (inches)	24" x 24" x 62"
Hand Sink	Stainless Steel 10" X 12" X 6" deep
Water Heater	120 VAC
Electrical Rating	1500 Watts 20A Dedicated Outlet
On Demand Hot Water	65 to 145 Degrees F
Mixing Valve	Manual mixing valve installed
Fresh Water Capacity	5 Gallon Removable Plastic Tank
Wastewater Capacity	6 Gallon Removable Plastic Tank
Soap Dispenser *	Sensor activated, touchless operation, Battery operated. Accepts 1200mL bag refill cartridges
Towel Dispenser*	Sensor activated, touchless operation, battery operated
Steel Type	301 Stainless Steel Construction
Certifications	NSF/ANSI 169
Features	Two locking and two non-locking 5 inch casters, handles for moving cabinet and hinged door with locking latch for internal access



Benefits

- **Sanitary:** All touchless. No need to make contact to activate soap, faucet or towels. Stainless steel cabinet is hygienic, easy to clean and sanitize.
- **Portable:** Can be positioned anywhere hand washing is needed
- **Durable:** All welded stainless steel construction.
- **Certifications:** Conforms to NSF construction and designed to meet state and local hand washing codes

Patent Pending

Product Compliance: Conforms to NSF/ANSI 169 standards

See Reverse Side for Drawings

Cleaning, Care & Installation

For proper cleaning, care and installation instructions, please visit our website at Elkay.com for downloadable PDFs.

* Make and model of touchless, electronic faucet, towel dispenser and soap dispenser may change and will have the same functionality and warranty.

PART: _____ QTY: _____
 PROJECT: _____
 CONTACT: _____
 DATE: _____
 NOTES: _____
 APPROVAL: _____

Elkay reserves the right to change product specifications without notice. Please visit elkay.com for the most current version of Elkay product specification sheets. This specification describes an Elkay product with design, quality, and functional benefits to the user. When making a comparison of other producers' offerings, be certain these features are not overlooked.

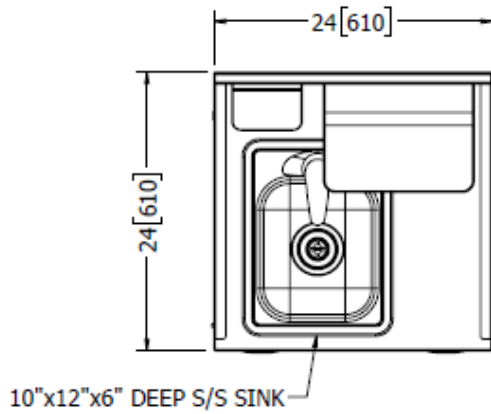

TOP VIEW



INTERNAL VIEW

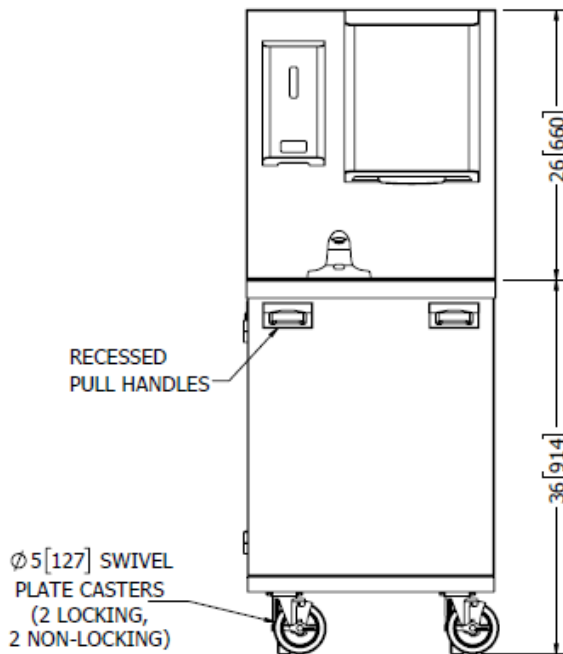

FRONT VIEW

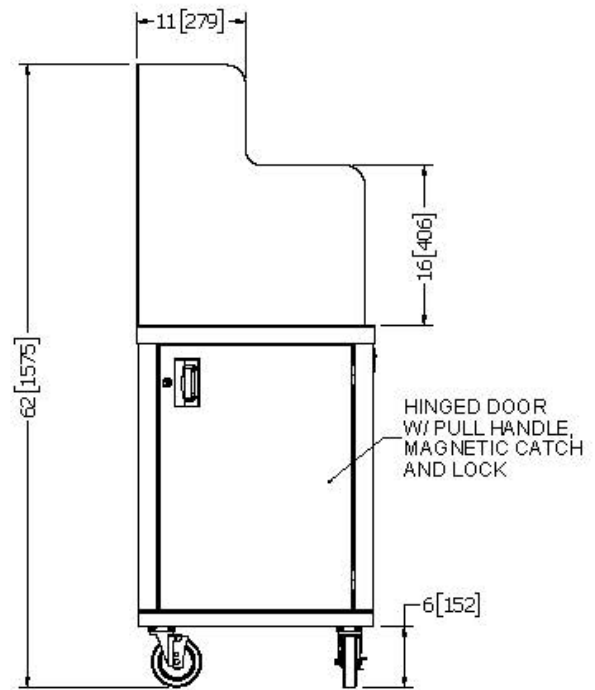

LEFT SIDE

WARRANTY:

Elkay Commercial Systems warranty provides a one year guarantee against defect in workmanship and materials.

Elkay reserves the right to change product specifications without notice. Please visit elkay.com for the most current version of Elkay product specification sheets. This specification describes an Elkay product with design, quality, and functional benefits to the user. When making a comparison of other producers' offerings, be certain these features are not overlooked.