



6A01

Foam Soap/Sanitizer Dispenser

Model 6A01-11—Surface-Mounted Foam Tank Type Vertical **Bradex**[®]

Diplomat Series

Product Materials

BODY: Heavy gauge stainless steel with exposed surfaces in architectural satin finish. Front has matching curvature to other Bradley Diplomat washroom accessories.

WALL PLATE: ABS plastic.

RESERVOIR: reusable, cap-sealed plastic tank, holds 27 oz.

BATTERY BOX: Plastic, holds (4), "AA" Alkaline batteries, not included.

INDICATOR LIGHTS: Green light = In "use" and dispensing.
Red flashing light = Low battery.

Capacity

27 oz (800 ml) of bulk foam soap and foam sanitizer

Operation

Place hands under spout and hold to dispense foaming liquid. (2"-3" sensing range.) Sight gauge indicates refill time. Refill by unlocking lock with special key (supplied), swinging open dispenser body. Remove cap to refill internal tank.

Installation

Verify all rough-in dimensions prior to installation. Secure separate mounting bracket with mounting screws (included) at holes provided. Unlock the cover. Open and remove tank. Secure unit to wall by installing the mounting screws. Install batteries (not included). Fill tank with premixed, bulk foam soap/sanitizer. Close and lock the cover.

Guide Specification

Soap/Sanitizer Dispenser: Bradley Corp. Diplomat Series Model 6A01: Surface-mounted automatic foam soap/sanitizer dispenser, with face formed with contemporary contours, radii, and finish matching related accessories in manufacturer's designer series. Capacity 27 oz (800 ml). Equipped with hinged cover and completely concealed mounting plate. Vandal resistant filler hole cover and sight gauge. Corrosion-resistant foam soap/sanitizer valve.

Overall dimensions: 4⁵/₈"W x 10¹/₁₆"H x 4³/₁₆"D.

MasterFormat Title: Commercial Toilet Accessories

MasterFormat Number: 10 28 13.13

OmniClass Title: Soap Holders, Dispensers

OmniClass Code: 23.40.20.21.34

Orders composed of products indicated as **Bradex**[®] will be available to ship in three days after receipt of order at the factory. There is no pricing penalty for this service from Bradley.

Page 1 of 2

11/11/2020

[View Latest Version](#)

This information is subject to change without notice.

Bradley_SoapDispenser_6A01



Model

6A01-11

Surface-Mounted Automatic Foam Soap/Sanitizer Dispenser

Finishes



Brushed Stainless

Product Compliance



ADA / ICC ANSI A117.1, Citation 309.3

Compatible Bradley Products

[6A20-110000 Hand Sanitizer/Soap Dispenser Stand](#)

For information on Warranties, Maintenance and BAA/ARRA Compliance, visit our web site at:
bradleycorp.com/products/accessories/.

© 2020 Bradley

P.O. Box 309, Menomonee Falls, WI 53052-0309

800 BRADLEY (800 272 3539)

+1 262 251 6000

bradleycorp.com



Dimensions

(mm)

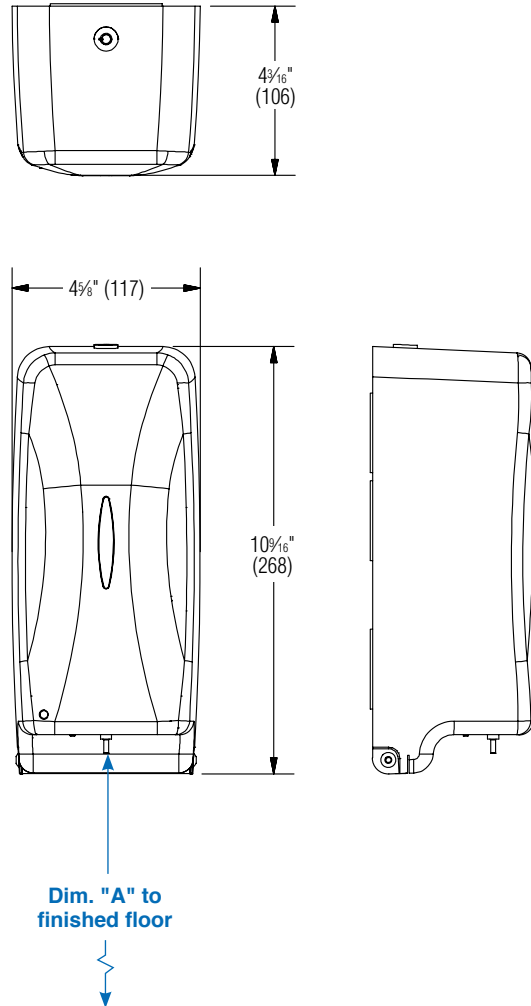

Dim. "A" Key Surface:	For Dim. "A"	Locate Top of Unit	Locate Bottom of Unit
Bottom of dispensing tube to finished floor	48" (1219)	58" (1473)	47 ¹ / ₁₆ " (1205)
	45" (1143)	55" (1397)	44 ¹ / ₁₆ " (1129)
	42" (1067)	52" (1321)	41 ¹ / ₁₆ " (1053)
	40" (1016)	50" (1270)	39 ¹ / ₁₆ " (1002)

Orders composed of products indicated as **Bradex**® will be available to ship in three days after receipt of order at the factory. There is no pricing penalty for this service from Bradley.

Page 2 of 2
 11/11/2020
 This information is subject to change without notice.
 Bradley_SoapDispenser_6A01

[View Latest Version](#)

© 2020 Bradley
 P.O. Box 309, Menomonee Falls, WI 53052-0309
 800 BRADLEY (800 272 3539) +1 262 251 6000
 bradleycorp.com