

Installation

Models 401, 4017

Recessed

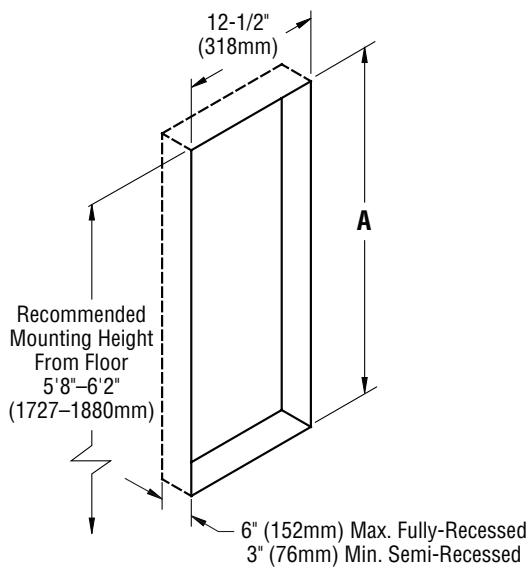

Surface-Mounted

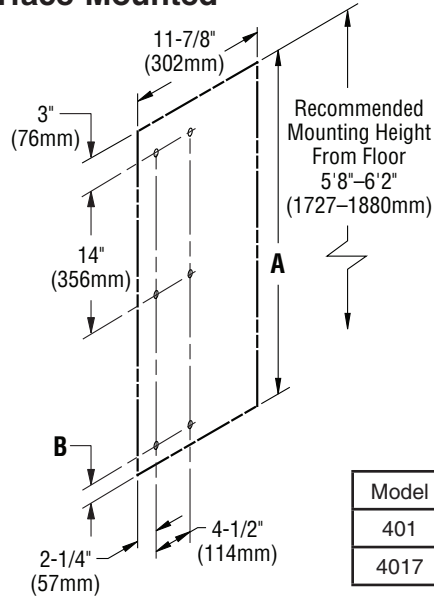

Additional information may be found on our Web site at bradleycorp.com

Model	Dim. A	Dim. B
401	26-3/8" (670mm)	—
4017	26-3/8" (670mm)	—

Service Parts

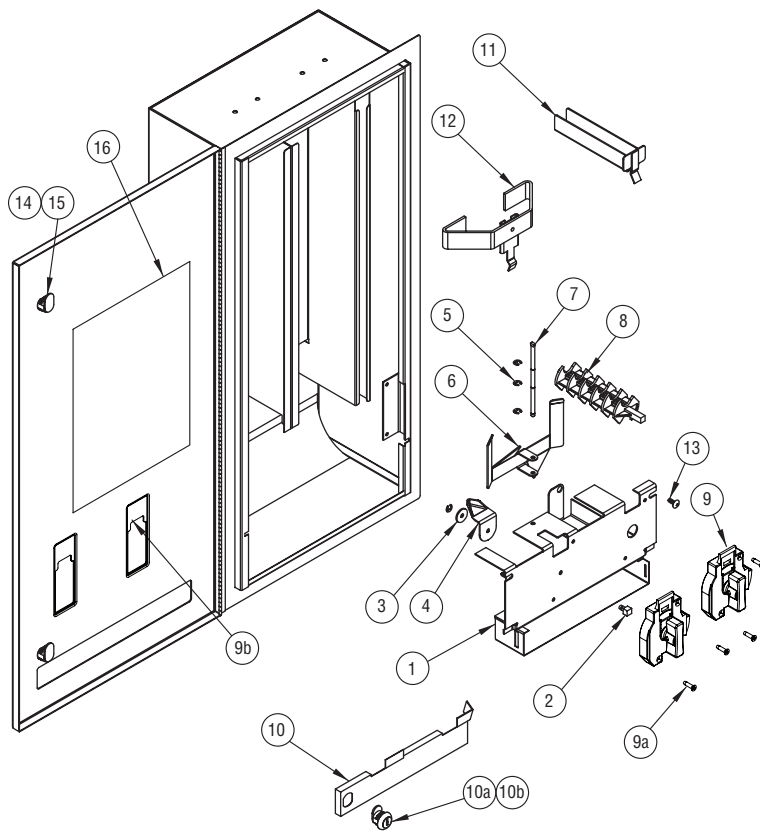

ITEM	PART NO.	DESCRIPTION
1 (includes 2-10)	S01-520040 S01-520042 S01-520045 S01-520043 S01-520044 S01-520E43	Free Coin Mounting Plate 10¢ Coin Mounting Plate 25¢ Coin Mounting Plate 50¢ Coin Mounting Plate \$1 Coin Mounting Plate € .50 Coin Mounting Plate
2	P10-517	Slave Shaft (requires P18-028)
3	P18-018	Flat Washer
4	270-072	Cam
5	P18-028	Retaining Ring
6	330-106	Napkin Paddle
7	330-107	Coined Shaft (requires P18-028)
8	P10-524	Tampon Rotor
9 (includes 9a & 9b)	A19-016 A19-017 A19-018 A19-019 A19-020	Free Coin Mechanism 10¢ Coin Mechanism 25¢ Coin Mechanism 50¢ Coin Mechanism \$1 Coin Mechanism
9a	P18-125	Screw for Coin Mechanism
9b	P20-034 P20-036 P20-037 P20-078 P20-117	Free Label for Coin Mechanism 10¢ Label for Coin Mechanism 25¢ Label for Coin Mechanism 50¢ Label for Coin Mechanism \$1 Label for Coin Mechanism
10	A18-037	Coin Box Cover w/Lock & Key
10a	P10-519	Lock/Cam for Coin Box
10b	P10-548	Key for Coin Box
11	S01-499	Tampon Weight
12	S01-374	Napkin Weight
13	P18-055	Screw #10-32 x 1/2"
14	P15-399	Lock for Door
15	P15-398	Key for Door
16	P20-039	Installation Instructions

Operation

To Load Napkins or Tampons

1. Remove napkin or tampon weight from center track.
2. Insert products into each channel.
3. Replace weight on top of product.

To Dispense Napkin or Tampon

1. Insert coin in coin slot, turn handle clockwise and release. When all products have been dispensed, the weight actuates the "EMPTY" indicator which blocks coin slot and prevents another coin from being inserted.

NOTE: For best vendor operating performance, product packages must meet the following size requirements: Napkins - 3" x 4-1/4" x 1"; Tampons - 5-1/8" long x 3/4" diameter tubes. Contact your local sanitary supply distributor to purchase product.

Maintenance

If Vendor Fails to Operate Properly

Make sure that:

1. Vendor is loaded with correct size napkins and tampons.
2. Damaged napkins or tampons are not jamming mechanism.
3. Weights are in place on top of napkins and tampons.
4. Napkin support tabs (fingers that napkins rest on) are in a straight, horizontal position.
5. Tampon rotor is properly installed with the pocket of the rotor in the UP position.
6. Coin box is not full.

To Replace or Convert Coin Mechanisms

1. Order new coin mechanism by part number for coin denomination desired (see above).
2. Remove existing coin mechanism by unfastening two screws.
3. Install new coin mechanism with two screws. **NOTE:** Make sure tampon cam is properly installed with pocket of rotor in UP position.

